

BIO-RAD LABORATORIES 2000 ALFRED NOBEL DRIVE HERCULES, CA 94547	MATERIAL SPECIFICATION (Non-Chemical)	PART NUMBER <small>[BAAN ITEM NUMBER]</small> 10011164	REV A

EXTENDED DESCRIPTION: BIOSCALE MINI PROFINITY EXACT CARTRIDGES, 1 AND 5 ML

ERP/PLM DESCRIPTION (30 Characters Max): MANUAL, EXACT CART, BIOSCALE

SPECIFICATIONS (ALL DIMS ARE REF ONLY)

SPECIFICATIONS:
SIZE: 3.5" x 4.25 "
COVER: 20# MOUNTIE MATTE OR EQUIV
PAPER: 20# MOUNTIE MATTE OR EQUIV
INK: COLOR THROUGHOUT
PAGES: 30
BINDING: STAPLED 4.25 WAY



SPECIAL INSTRUCTIONS:

ATTRIBUTES			
ESD Sensitive	WEEE	CDF	WAREHOUSE ACCEPTED (DTS)
<input type="checkbox"/> Yes <input checked="" type="checkbox"/> No	<input type="checkbox"/> Yes <input checked="" type="checkbox"/> No	<input type="checkbox"/> Yes <input checked="" type="checkbox"/> No	<input checked="" type="checkbox"/> Yes <input type="checkbox"/> No

QUALIFIED PARTS						
MANUFACTURER	MANUFACTURER'S PART NUMBER	SUPPLIER (VENDOR) <small>[BUSINESS PARTNER NUMBER]</small>	SUPPLIER PART NUMBER	COMMENTS	RoHS (Y/N)	Eng R&D
						Appr / Date
LSG COPY CENTER	10011164	0002401000			N	LK11/11/07

EQUIVALENT SUBSTITUTIONS AUTHORIZED: Yes No

RECEIVING	
METHODOLOGY:	N/A
PACKAGING & SHIPPING:	Material shall be packaged and shipped in a manner that will insure protection of the material from the adverse effects of moisture, dirt and other forms of contamination or the adverse effects of temperature.

ORIGINATOR: DON GUEFFROY	R&D APPROVAL: ERIC LARSON	APPROVAL DATE: 11/20/07	BP#: BP-015276
-----------------------------	------------------------------	----------------------------	----------------

Bio-Scale™ Mini
Profinity eXact™
Cartridges, 1 and 5 ml

Instruction Manual

Catalog #
732-4646
732-4648

BIO-RAD

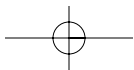
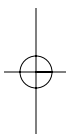

Table of Contents

Section 1	Introduction	1
Section 2	Product Information	2
Section 3	Connection to Low-Pressure Chromatography Systems	7
Section 4	Connection to Medium- and High- Pressure Chromatography Systems .	11
4.1	BioLogic DuoFlow™ Systems	11
4.2	HPLC Systems	12
4.3	FPLC Systems.....	13
Section 5	Buffers and Methods	14
Section 6	Quick Solubility Screening Protocol.....	16
Section 7	Preparation of <i>E. coli</i> Lysate	19
Section 8	Cartridge Preparation and Purification Protocol	20



Bio-Rad Laboratories, Inc.
2000 Alfred Nobel Dr.
Hercules, CA 94547 USA
510-741-1000
1-800-424-6723

10011164 Rev A

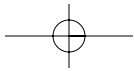

Section 9 Scaling Up.....	23
Section 10 Regenerating, Cleaning, and Storage	23
Section 11 Troubleshooting Guide.....	26
Section 12 Ordering Information.....	28
Section 13 References	29
Section 14 Legal Notices	29

Section 1 Introduction

Bio-Scale Mini cartridges are convenient, disposable, prepacked chromatography cartridges. Patented* column design assures leak-free operation with any low pressure chromatography system. Bio-Scale Mini cartridges are available for a variety of chromatographic techniques such as desalting, ion exchange, hydrophobic interaction, and affinity chromatography.

Bio-Scale Mini Profinity eXact cartridges are packed with Profinity eXact (EXact Affinity Cleavage Technology) purification resin. This agarose-based affinity chromatography resin utilizes an immobilized, modified protease that selectively binds the fusion protein and cleaves the affinity tag on-column under controlled conditions, releasing the purified target protein which contains only its native amino acid sequence. This innovative resin technology improves the efficiency of recombinant protein purification, and is the only affinity chromatography platform that completes the purification and tag removal process in a single step.

*U.S. patent 7,208,087

Section 2 Product Information

Bio-Scale Mini cartridges are prepacked chromatography cartridges supplied ready for use in 1 ml and 5 ml sizes. Bio-Scale Mini cartridges can be used with any liquid chromatography system capable of setting a high pressure limit of 45 psi (equivalent to 3 bar or 300 kPa). Alternatively, luer fittings offer convenient connection directly to a Luer-Lok syringe for quick, one-step purification. See Ordering Information, Section 12, for a listing of the complete Bio-Scale Mini cartridge product line.

Table 1. Bio-Scale Mini Profinity eXact cartridge specifications.

Sizes	1 ml and 5 ml bed volumes
Dimensions	1 ml: 40 mm length x 5.6 mm inner diameter 5 ml: 40 mm length x 12.6 mm inner diameter
Maximum pressure tolerance	45 psi
Maximum flow rate	1 ml: 3 ml/min (720 cm ³ /hr) 5 ml: 10 ml/min (480 cm ³ /hr)
Fittings	Female luer inlet and male luer outlet
Column material	Polypropylene
Frit material	Polyethylene (HDPE)
Shipping conditions	100 mM sodium phosphate, 0.02% sodium azide, pH 7.2
Storage recommendations	100 mM sodium phosphate, 0.02% sodium azide, pH 7.2
Autoclavability	Not autoclavable

Table 2. Profinity eXact resin specifications.

Functional ligand	Mutant subtilisin
Base bead	Superflow 6% agarose
Particle size range	60–160 μm
Recommended linear flow rate	<1,000 cm/hr at 25°C
Maximum operating pressure	45 psi
Chemical compatibility	See Table 3
Storage	4°C
Shelf life in storage buffer	>1 year at 4°C
Operational temperature	4–40°C

4**Table 3. Buffer and chemical compatibilities for Profinity eXact cartridges.**

Reagent Group	Description	Stability
Triggering Ions	F ⁻ , Cl ⁻ , N ₃ ⁻ , NO ₂ ⁻ , CO ₂ ⁻	Do not use in lysis and wash buffers. See Table 5 for use as trigger in elution buffer.
Salts	Sodium Acetate	≤3M
	NaCl or KCl	Do not use in lysis and wash buffers.
Buffers	Tris-HCl	Substitute Tris-acetate or Tris-phosphate.
Acids	HCl	Do not use. Substitute acetic or phosphoric acid.
Detergents	Non-ionic	≤5% (w/v)
	Zwitterionic	≤5% (w/v)
	Ionic	Do not use.
Protease inhibitors	PMSF, CalBioChem cocktail, Roche Protease Inhibitor cOmplete mini tablet	1X
	BD Biosciences cocktail	2X
Lysis Solutions	Lysis & Extraction Reagent (Bio-Rad), B-PER phosphate (Pierce), BugBuster (EMD), FastBreak Cell Lysis (Promega)	1X
	ReadyPreps Lysis (Epicentre), CellLytic Express (Sigma)	Do not use.

5

Reagent Group	Description	Stability
Denaturants	Guanidine-HCl	Do not use in lysis and wash buffers.
	Urea	Up to 2 M with no drop in binding capacity. At 4 M there may be some loss of binding capacity. At 8 M, binding capacity and target protein purity will be reduced.
Other additives	CaCl ₂	≤5 mM when used with MES, MOPS, or PIPES buffers. Do not use with phosphate buffers.
	MgCl ₂	≤5 mM. Do not use with fluoride containing buffers. Use NaN ₃ as an alternate triggering ion.

For a complete list of chemical compatibility, refer to the Profinity eXact Purification System instruction manual.

Section 3 Connection to Low-Pressure Chromatography Systems

Bio-Scale Mini cartridges are ideal for use with Bio-Rad's BioLogic™ LP chromatography system, Econo™ gradient pump, the patented* Model EP-1 Econo pump, and all low-pressure chromatography instruments. Bio-Scale Mini cartridges can be conveniently connected directly to the system using the luer fittings on the cartridge.

1. Install 1.6 mm inner diameter (ID) tubing in the pumphead. Adjust the platen pressure screw (on pumphead) using a screwdriver or coin. Turn the screw counterclockwise as far as it will go, then turn clockwise three full turns. Assemble with fittings and lock rings as shown in Figure 1.

* US patent 5,135,658

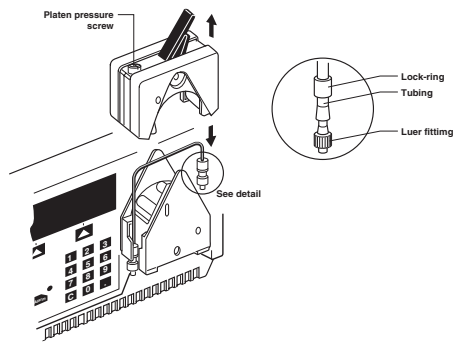

Fig. 1. BioLogic LP system setup. (Use orange lock rings and medium size barb fittings with 1.6 mm tubing.)

- To maximize gradient accuracy and to apply samples efficiently, install 1.6 mm ID tubing from the pump to the MV-6 sample inject valve (if available). If using the MV-6 sample inject valve, turn the knob counterclockwise as far as it will go so it corresponds to the printed diagram on the valve (see Figure 2).

8

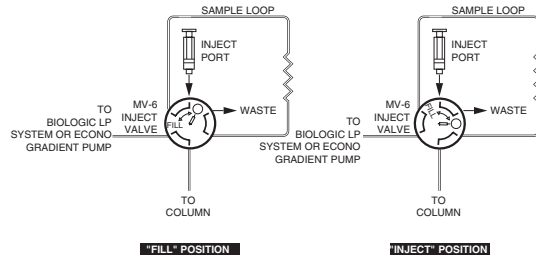

Fig. 2. Connecting to an MV-6 valve.

- Connect the inlet of the cartridge to the male luer fitting on the MV-6 sample inject valve (see Figure 2). If not using the MV-6 sample inject valve, connect a barb to male luer fitting on the 1.6 mm ID tubing, then connect to the top of the female luer on the Bio-Scale Mini cartridge. For optimum performance, a cartridge should be mounted vertically with the arrow on the cartridge pointing downward (see Figure 3).

9

4. Connect the cartridge outlet to the 1.6 mm ID tubing leading to the BioLogic LP system optics module or to the Model EM-1 Econo UV monitor. It is recommended to use the shortest length (approximately 10 cm) of 1.6 mm ID tubing. Connect a barb to female luer to the 1.6 mm ID tubing, then connect to the bottom of the male luer on the Bio-Scale Mini cartridge.



Fig. 3. Cartridge and fittings. Luer fittings and column: a cartridge should be mounted vertically with the arrow on the cartridge pointing downward.

10

Section 4 Connection to Medium and High-Pressure Chromatography Systems

Bio-Scale Mini cartridges can be connected to any liquid chromatography system, provided that the system does not exceed the maximum pressure limit of the cartridges (3 bar, 45 psi or 300 kPa). It is recommended that the system pressure limit be set according to the cartridge pressure limit. Pressures in excess of 3 bar are usually caused by restrictions in tubing or detector cells downstream from the cartridge. Bio-Rad offers two fitting kits for easy connection of a Bio-Scale Mini cartridge to a BioLogic DuoFlow™, HPLC-, or FPLC-type system.

4.1 BioLogic DuoFlow Systems

The luer to BioLogic system fittings kit (catalog #732-0113) includes 1/4-28 female to male luer and 1/4-28 female to female luer to connect one Bio-Scale Mini cartridge to the BioLogic DuoFlow system. (see Figure 4)

11

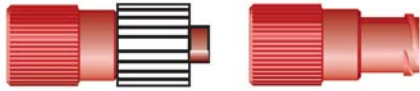

Fig. 4. Luer to 1/4-28 adaptor.

4.2 HPLC Systems

The luer to 10-32 adaptor fittings kit (catalog #732-0112) provides fittings necessary to connect the Bio-Scale Mini cartridge to nut and ferrule type fittings found on most HPLC systems. Alternatively, the cartridge can be connected to HPLC systems via a low dead-volume 1/16 inch union with a new piece of stainless-steel tubing attached to the union. Simply slip a short length of the 0.8 mm ID tubing over the 1/16 inch OD stainless-steel tubing to a distance of 1 cm.

12

4.3 FPLC Systems

The luer to M6 adaptor fittings kit (catalog #732-0111) provides fittings necessary to connect the Bio-Scale Mini cartridge to the M6 fittings found on FPLC or related systems. Alternatively, connection can be made by using one GE Healthcare Union luerlock female to M6 female fitting (GE 18-1027-12) and one Upchurch P-686, female slip luer to male M6 fitting or GE 18-1027-62, Union luerlock female to M6 male fitting. To prevent tubing or cartridge failure, do not exceed the maximum recommended flow rate of the cartridge.

* Fittings kit ordering information can be found within the Ordering Information section of this manual.

13

Section 5

Buffers and Methods

Bio-Scale Mini Profinity eXact cartridges can be run using either native or denaturing purification protocols. Under native conditions, proteins are purified using buffers that help retain the natural folded structure of the target protein. Under denaturing conditions, a strong chaotrope (e.g. urea) is included in the bind/wash buffer and elution buffer, allowing target proteins to be purified in an unfolded or partially folded state. The recommended buffer compositions and triggering anions are provided in the following tables. Note that some loss in binding capacity may be observed when buffers used contain greater than 2 M urea. Additionally, urea concentrations greater than 4 M may result in decreased target protein purity.

Table 4. Buffer composition.

Bind/wash buffer*	100 mM sodium phosphate, pH 7.2
Elution buffer*	100 mM sodium phosphate, 100 mM sodium fluoride, pH 7.2
Regeneration	100 mM phosphoric acid
Storage	0.02% sodium azide, 100 mM sodium phosphate, pH 7.2

* Add urea to the bind/wash buffer and elution buffer in order to purify proteins under denaturing conditions.

Table 5. Triggering anions.

Anion	Compound	Fast Cleavage	Slow Cleavage
F ⁻	NaF, KF	100 mM	5 mM
N ₃ ⁻	NaN ₃	10 mM	1 mM
NO ₂ ⁻	NaNO ₂	5 mM	1 mM
CO ₂ ⁻	NaHCO ₂	1000 mM	25 mM
Cl ⁻	NaCl, KCl	>1000 mM	75 mM

Section 6

Quick Solubility Screening Protocol

Before choosing a native or denaturing purification protocol, it is useful to determine the approximate expression level of a protein, and to determine if the overexpressed target protein partitions into the soluble or insoluble fraction. Soluble proteins are typically purified with the native purification procedure, while insoluble proteins can be solubilized in urea and purified with the denaturing procedure.

The following procedure provides a quick screen for solubility and expression level:

1. Pellet ~ 2 ml of *E. coli* culture by centrifugation at 16,000 x g for 1 min at 4°C.
2. Resuspend the pellet in 500 µl of bind/wash buffer and sonicate for 60 sec, on ice, in 10 sec pulses. Remove 50 µl of the sonicate and label as the "Total" sample. Centrifuge the lysate at 16,000 x g for 5 min at 4°C. Transfer the

16

supernatant to a clean tube. Remove 50 µl of the supernatant, and label the tube "Soluble".

3. Resuspend the insoluble pellet in 500 µl of bind/wash buffer containing 4 M urea. Centrifuge the lysate at 16,000 x g for 5 min at 4°C. Remove 50 µl of the supernatant, and label "Insoluble".
4. To each of the 50 µl samples, add 150 µl of Laemmli buffer, and heat for 5 min at 95°C.
5. Load 10 µl of each sample on an SDS-PAGE gel.
6. Examine the soluble and insoluble fractions for the target protein. Approximate the expression level, and determine partitioning of the target protein.

A partitioning profile of a soluble target protein can be seen in Figure 5.

17

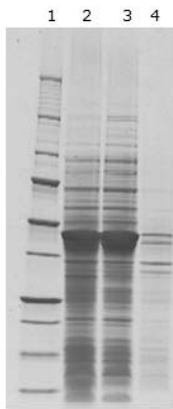

Fig. 5. Partitioning profile. Precision Plus Protein™ molecular weight markers were loaded in lane 1, followed by the total, soluble, and insoluble fractions in lanes 2–4 respectively. The gel depicts Profinity eXact-tagged Maltose Binding Protein, which partitions into the soluble fraction and can be purified using the native purification protocol. A representative chromatogram and gel for the purification of this target protein is shown in Fig. 6.

18

Section 7 Preparation of *E. coli* Lysate

For *E. coli* cultures expressing medium to high levels of Profinity eXact-tagged proteins, ($\geq 10\%$ of total protein), 50 ml of culture will yield sufficient material for a 1 ml cartridge purification, and 250 ml of culture will yield sufficient material for a 5 ml cartridge purification run. For cultures expressing protein at low levels ($\leq 10\%$ of total protein), the culture volumes will need to be determined empirically for each protein.

Lysate Preparation

1. Harvest cells by centrifugation.
2. Determine weight of cell pellet and resuspend in 10 volumes of bind/wash buffer (50 ml of culture typically yields 0.5 g of paste, resulting in approximately 5 ml of lysate).
3. Sonicate the lysate (on ice) for 3 minutes.
4. Centrifuge the lysate at $\geq 16,000 \times g$ for 30 min at 4°C.

19

5. Remove the supernatant, and filter through a 0.45 μ M filter before applying to the cartridge.

Section 8 Cartridge Preparation and Purification Protocol

To prepare a cartridge, remove the end plugs and connect the cartridge to the chromatography system. The cartridge is now ready for use. The following 1 ml cartridge purification protocol is a general guideline for first time users. Flow rates for 5 ml cartridges are shown in parentheses. The kinetics of cleavage are target protein specific and may require optimization to maximize yield. See Figure 6 for a representative purification profile using the following protocol. Refer to the Profinity eXact System Manual for complete details.

Purification Protocol

1. Equilibrate the cartridge with 10 column volumes (CV) of bind/wash buffer at 3 ml/min (10 ml/min).
2. Load the sample lysate at 1 ml/min (5 ml/min).
3. Wash the cartridge with 10 CV of bind/wash buffer at 3 ml/min (10 ml/min).
4. Equilibrate cartridge with 2 CV of elution buffer at 3 ml/min (10 ml/min)*.
5. Stop flow and incubate for 30 minutes**.
6. Elute purified protein with 5 CV of elution buffer at 3 ml/min (10 ml/min).

* Alternative elution protocol: Pump 5 CV of elution buffer at 0.1 ml/min (0.5 ml/min) at room temperature.

** Increased incubation time, 2–4 hr at 25°C or 12–24 hr at 4°C, may be necessary for complete cleavage of some proteins.

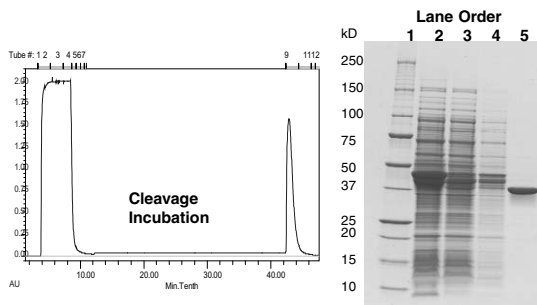

Fig. 6. Native purification. Purification of Profinity eXact-tagged Maltose Binding Protein from the soluble fraction using a BioLogic DuoFlow system. 5 ml of lysate (5 CV) prepared from 50 ml of *E. coli* culture was loaded onto a 1 ml cartridge. The cartridge was washed with 10 CV of bind/wash buffer, and purified protein was eluted with 5 CV of elution buffer following a 30 min cleavage incubation. The purified product was determined to be 99.5% pure by Quantity One® software analysis. Lane 1, Precision Plus Protein unstained standards; lane 2, soluble lysate; lane 3, flow-through; lane 4, wash; lane 5, purified product.

22

Section 9 Scaling Up

Bio-Scale Mini cartridges are available in 1 ml and 5 ml cartridge formats. The Profinity eXact resin is also available in 10 ml bottles. For quick scale-up, two or more cartridges may be connected in series; backpressure will increase with cartridges in series, so care should be taken to maintain an overall system pressure ≤ 45 psi. In addition, Bio-Rad carries an extensive line of empty chromatography columns from laboratory scale to process scale. Inquire with your local Bio-Rad representative or go online to www.bio-rad.com.

Section 10 Regenerating, Cleaning, and Storage

Protein cross-contamination, frit clogging, and increased backpressure may result from cartridge overuse. It is recommended to dispose of a

23

cartridge after five purifications, however, the following regeneration procedure may be used to prolong the useful lifespan of a cartridge. In addition, in order to avoid cross-contamination it is recommended that single cartridges be designated for single proteins. In order to reuse a cartridge, the Profinity eXact tag, which is bound tightly to the functional ligand, MUST be removed. Therefore, to maintain good cartridge flow properties, and to prepare the cartridge for a subsequent purification, it is recommended that the cartridge be regenerated after each use. For the 1 ml cartridges, run the regeneration protocol at 3 ml/min. For the 5 ml cartridges, run the regeneration protocol at 10 ml/min.

Regeneration and Storage

1. After elution of the purified protein, wash the cartridge with 5 CV of bind/wash buffer.
2. Regenerate the cartridge with 3 CV of 100 mM phosphoric acid.
3. Neutralize the cartridge with 5 CV of bind/wash buffer.

24

Note: The resin may also be cleaned with 0.1 M NaOH. Limit exposure time to 3 hours and immediately neutralize with 5 CV of bind/wash buffer. Regeneration of the resin with phosphoric acid is still necessary, as NaOH alone will not efficiently remove the Profinity eXact tag from the resin.

25

Section 11

Troubleshooting Guide

Problem	Possible Cause	Solution
Cartridge clogging or slow flow rate	Particulates in samples or buffers	Filter all samples and buffers through 0.45 μ M filter prior to application
	Sample too viscous	Add nuclease to lysate to degrade DNA
No target protein in eluant	Low level of target protein in starting material	Check expression level by SDS-PAGE
	Target protein not binding	Used resin must be regenerated before reuse. Follow regeneration protocol in Section 10
	Inaccessible tag	Clone into pPAL's Spe I site
Target protein in flowthrough or wash fractions	Intrinsic cleavage	Ensure no chloride ions are present in lysate or bind/wash buffers. Perform purification at 4°C. Clone into pPAL's Spe I site
Uncomplete elution	No or slow cleavage	Lengthen cleavage incubation step. Clone into pPAL's Spe I site

26

Problem	Possible Cause	Solution
Precipitation during purification	Binding capacity of cartridge exceeded	Load less sample
	Protein aggregation	Include detergent or glycerol in buffers

27

Section 12 Ordering Information

Cartridges

Catalog #	Description
732-4646	Bio-Scale Mini Profinity eXact cartridge , 2 x 1 ml cartridge
732-4648	Bio-Scale Mini Profinity eXact cartridge , 1 x 5 ml cartridge

For the most up to date list of other cartridge offerings, please visit online at www.bio-rad.com/cartridges/

Fittings, Tubing, & Fittings Kits

Catalog #	Description
731-8225	1.6 mM Barb to Male Luer
731-8222	1.6 mM Barb to Female Luer
732-0111	Luer to M6 Adaptor Fittings Kit , includes luer to M6 fitting to connect to an FPLC system
732-0112	Luer to 10-32 Adaptor Fittings Kit , includes luer to polypropylene/Teflon 10-32 fittings to connect 1 cartridge to an HPLC system
732-0113	Luer to BioLogic System Fittings Kit , includes 1/4-28 female to male luer and 1/4-28 female to female luer to connect 1 cartridge to the BioLogic DuoFlow system

28

Section 13 References

Ruan, B et al. Engineering subtilisin into a fluoride-triggered processing protease useful for one-step purification. *Biochemistry* 43, 14539-46 (2004)

Section 14 Legal Notices

B-PER is a trademark of Pierce Biotechnology, Inc.

BugBuster is a trademark of Novagen, Inc.

Cellytic is trademark of Sigma-Aldrich
Biotechnology LP and Sigma Aldrich Co.

cOmpete is a trademark of a member of the Roche
Group.

FastBreak is trademark of Promega Corporation.

FPLC is a trademark of GE Healthcare.

ReadyPreps is a trademark of Epicentre
Technologies Corporation.

Teflon is a trademark of El du Pont de Nemours and
Co.

29

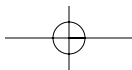

Profinity eXact™ vectors, tags, and resins are exclusively licensed under patent rights of Potomac Affinity Proteins. This product is intended for research purposes only. For commercial applications or manufacturing using these products, commercial licenses can be obtained by contacting the Life Science Group Chromatography Marketing Manager, Bio-Rad Laboratories, Inc., 6000 Alfred Nobel Drive, Hercules, CA 94547, Tel (800) 4BIORAD.

